

High Capacity Telehandlers

TF50.8





PERFORMANCE AND FEATURES	TF50.8T-170-HF	TF50.8TCS-170-HF	TF50.8TCS-170-CVT-HF
Performance			
Total unladen weight (kg)	9500	9700	9750
Maximum capacity (kg)	5000	5000	5000
Lifting height (m)	7,8	7,8	7,8
Maximum reach (m)	4,2	4,2	4,2
Maximum operating height (m)	7,8	7,8	7,8
Maximum operating reach (m)	1,4	1,4	1,4
Capacity at maximum height (kg)	5000	5000	5000
Capacity at maximum reach (kg)	1600	1600	1600
Lateral boom movement (mm)	-	-	-
Tilting correction (%)	± 8	± 8	± 8
Boom sections	2	2	2
PowerTrain			
Turbo motor	FPT NEF45	FPT NEF45	FPT NEF45
Displacement/cylinders	4500/4	4500/4	4500/4
Engine Power (kW/HP)	125/170	125/170	125/170
Anti-pollution technology	STAGE V, SCR+DOC+DPF	STAGE V, SCR+DOC+DPF	STAGE V, SCR+DOC+DPF
Reversible fan	○	○	○
Maximum speed (km/h)	40	40	40
Fuel tank (l)	140	140	140
AdBlue tank (l)	18	18	18
Hydrostatic transmission	● - 2V	● - 2V	CVTronic
EPD	Plus	Plus	Plus
Auto-revving joystick	●	●	●
Axles - Reducers	Axial, Epicyclic	Axial, Epicyclic	Axial, Epicyclic
Machine brakes	Dry disc	Dry disc	Dry disc
Automatic parking brake	●	●	●
Hydraulic			
Hydraulic pump	HF*	HF*	HF*
Flow rate/pressure (l/min - bar)	160 - 210	160 - 210	160 - 210
Hydraulic tank	100	100	100
Hydraulic outlet at the top of the boom	●	●	●
Rear hydraulic outlets	○	○	○
Cab			
Cab configuration	Premium	Premium	Premium
ASCS Adaptive Stability Control System	Full	Full	Full
FOPS LIV II cab	●	●	●
ROPS cab	●	●	●
Cab commands	Electronic joystick	Electronic joystick	Electronic joystick
Tilting Cab	-	-	-
Reverse shuttle	Dual reverse	Dual reverse	Dual reverse
Configuration			
Cab suspension	-	●	●
Boom suspension	●	●	●
Suspension on axles	-	-	-
Work headlights on cab	●	●	●
Sun blind	●	●	●
Tac-lock	●	●	●
Provision for a platform	○	○	○
Two floating forks	●	●	●
Inching-Control	●	●	●
Four-wheel drive	●	●	●
Four-wheel steering	●	●	●
Three steering modes	●	●	●
Standard tyres	500/70R24	500/70R24	500/70R24
Optional tyres	440/80-R24; 600/55-26.5; 500/70-R24, 17.5-25	440/80-R24; 600/55-26.5; 500/70-R24, 17.5-25	440/80-R24; 600/55-26.5; 500/70-R24, 17.5-25
Stabilisers	-	-	-
Turret rotation	-	-	-
Type approval as an agricultural tractor	○	○	○
Approval with PNEUMATIC braking	○	○	○
Approval with HYDRAULIC braking	○	○	○
PTO	-	-	-
3-point linkage	-	-	-

*LS + FS + oversized distributor

- Not Available
● Standard
○ Optional

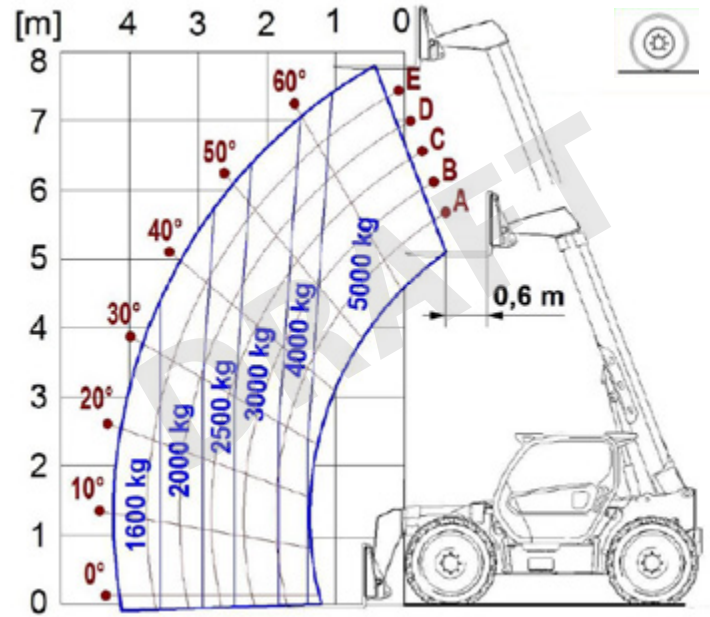

TF50.8

Dimensions



	TF50.8		
A (mm)	4870		
B (mm)	1170		
C (mm)	3050		
D (mm)	650		
E (mm)	4360		
F (mm)	440		
H (mm)	2400		
M (mm)	1010		
P (mm)	2530		
R (mm)	3830		
S (mm)	4800		
Z (mm)	850		

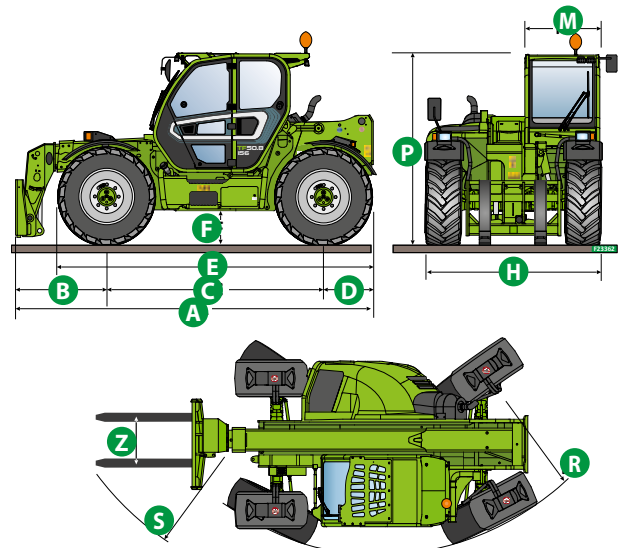

Your Merlo dealer



MERLO S.P.A.

Via Nazionale, 9

12010 S. Defendente di Cervasca, (Cuneo) Italia

Tel. +39 0171 614111

Fax +39 0171 684101

info@merlo.com

www.merlo.com

